

REVISIONS

E.C. NO.	REV.	DESCRIPTION	BY	DATE
0101	B	ADDED VIEW	CE	6/04
0303	C	PARTS CHANGED	SH	7/06
0748	D	NOTES ADDED	SH	8/08

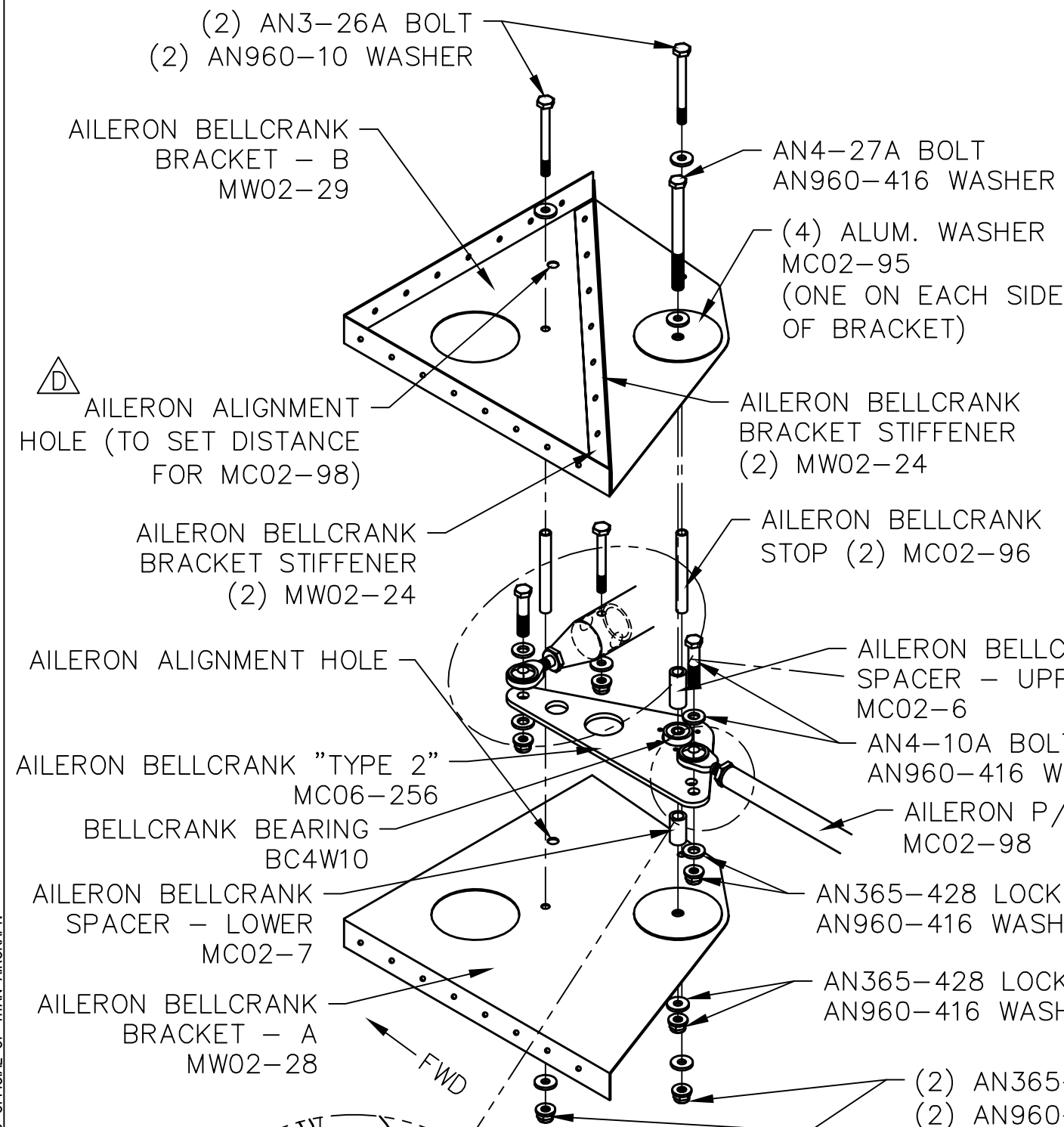

NOTE:

- ASSEMBLE BELLCRANK, BELLCRANK BEARING, BRACKETS, SPACERS, AND AILERON STOPS AS SHOWN.
- ASSEMBLE AILERON P/P MAIN TUBE AND AILERON P/P ROD ON TOP OF BELLCRANK.
- ALIGN THE PRE-DRILLED HOLES IN THE AILERON P/P TUBE END SO THEY DO NOT INTERFERE WITH THE 3/16" DIA. AN3-13A BOLT THAT HOLDS THE AILERON P/P TUBE END IN PLACE.
- USE (18) SD41BS RIVETS WHEN ATTACHING AILERON BELLCRANK BRACKET STIFFENERS (MW02-24).
- TO RIG THE AILERON IT WILL BE NECESSARY TO DISCONNECT THE AILERON MAIN P/P TUBE (MC02-97) TEMPORARILY & INSERT THE RIGGING BOLT THRU THE BELLCRANK ALIGNMENT HOLES. ALIGN AILERON W/ TRAILING EDGE OF WING, WHEN SATISFIED ADJUST THE AILERON P/P TUBE (MC02-98) TO ATTACH TO BELLCRANK.

DRILL THRU 3/16" AND INSTALL AN3-13A BOLT

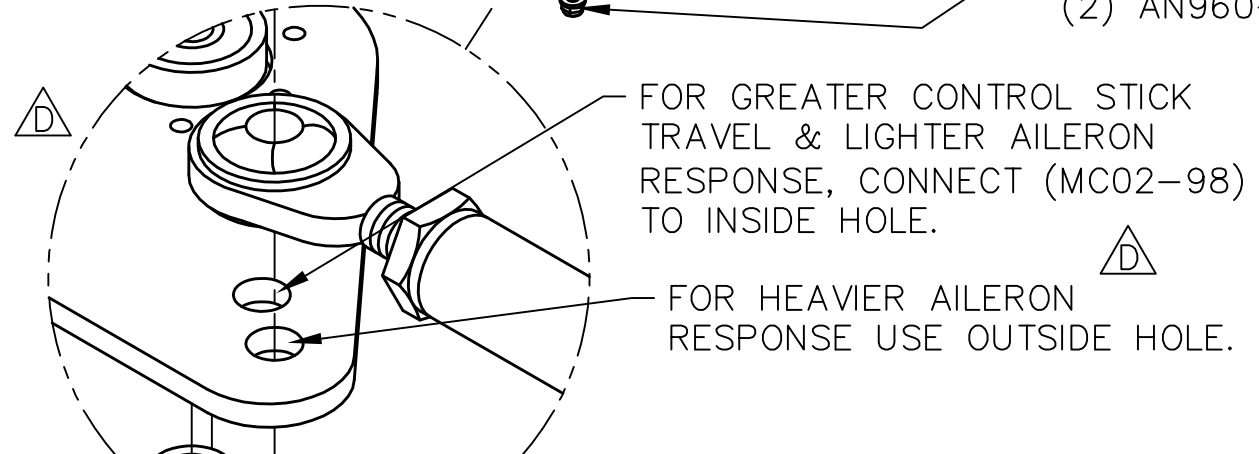
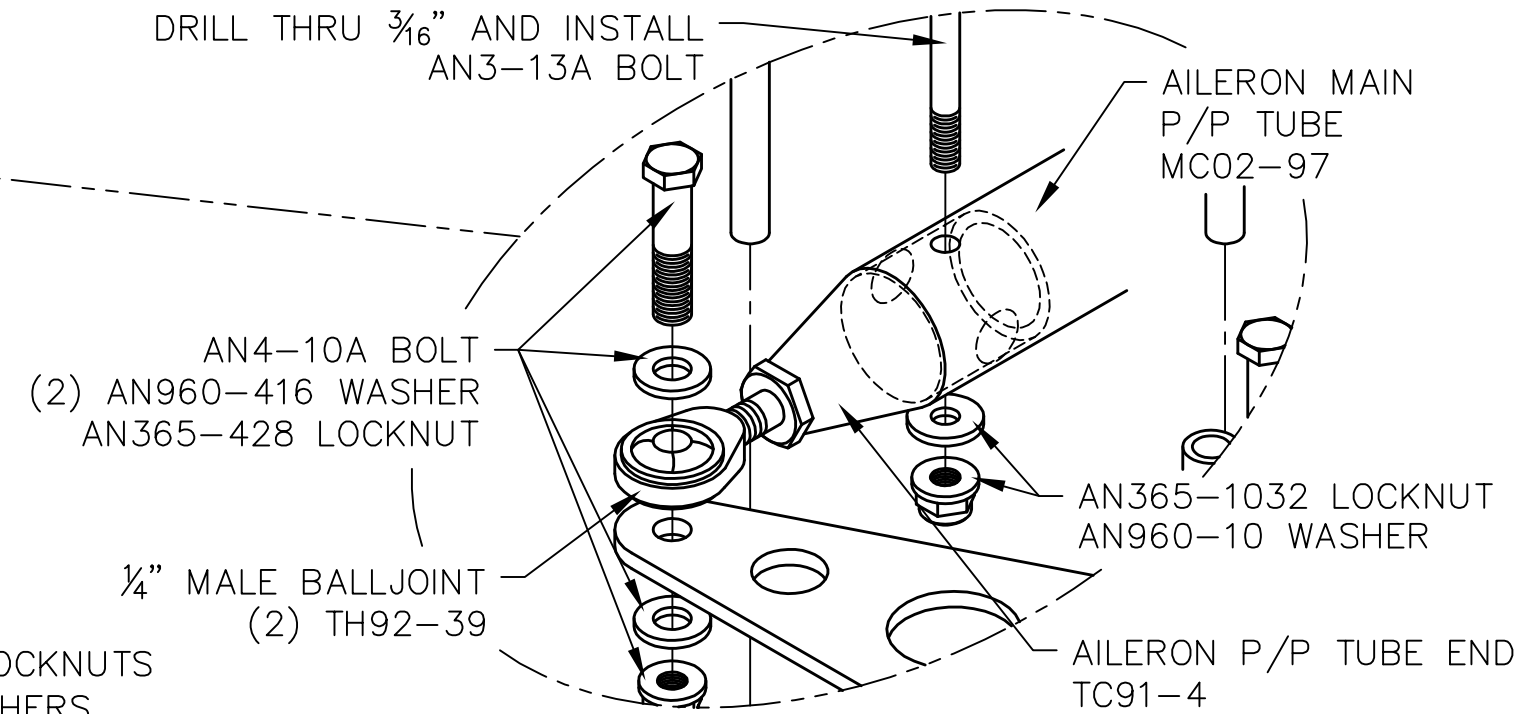

(LEFT SIDE SHOWN)
(RIGHT SIDE OPPOSITE)

DRAWN C.EMERY	DATE 11/20/03
CHECKED	DATE
APPROVED	DATE



TITAN AIRCRAFT SUPPLY
1419 STATE ROUTE 45 SOUTH
AUSTINBURG, OHIO 44010

DETAIL NAME AILERON BELLCRANK PUSH/PULL ROD ASSEMBLY INST.	
SCALE N/A	PART NO. N/A
ASSEMBLY NAME T-51 MUSTANG	
PART NO. N/A	DRAWING NO.
DRAWING NO. B T51-03-INS-0941-D	