

THIS DOCUMENT PROPRIETARY TO TITAN AIRCRAFT, AND IS NOT TO BE USED, CIRCULATED, REPRODUCED, COPIED, OR DISCLOSED IN ANY MANNER WITHOUT PRIOR WRITTEN PERMISSION OF AN AUTHORIZED OFFICIAL OF TITAN AIRCRAFT.

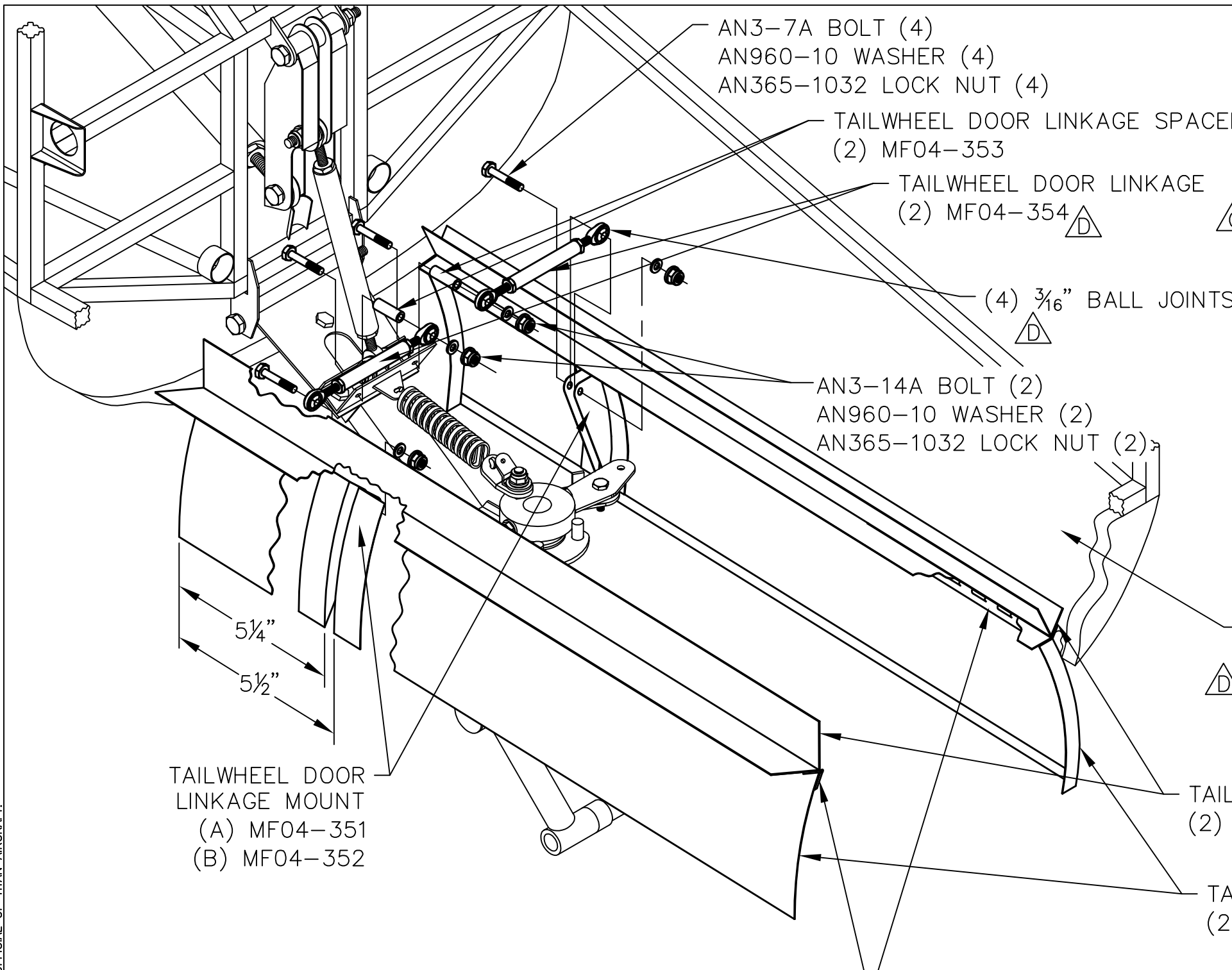

AN3-7A BOLT (4)
 AN960-10 WASHER (4)
 AN365-1032 LOCK NUT (4)

TAILWHEEL DOOR LINKAGE SPACER
 (2) MF04-353

TAILWHEEL DOOR LINKAGE
 (2) MF04-354 $\triangle D$

(4) $\frac{3}{16}$ " BALL JOINTS
 $\triangle D$

AN3-14A BOLT (2)
 AN960-10 WASHER (2)
 AN365-1032 LOCK NUT (2)

$\triangle C$

NOTES:

- MOUNT THE HINGES TO THE TAILWHEEL DOORS BEFORE POSITIONING ON THE AIRCRAFT.
- USE ACS42BS RIVETS WHEN MOUNTING THE HINGES.
- POSITION THE THE TAILWHEEL DOORS IN PLACE, BE SURE WHEN CLOSED THEY MEET IN THE CENTER OF THE AIRCRAFT, BUT DO NOT TOUCH.
- THE TAILWHEEL DOORS ARE SMALLER THEN THE OPENING BETWEEN STATIONS #11 & #12, BE SURE TO POSITION THE DOORS AS FAR FWD AS POSSIBLE. (HAVING THE BOTTOM SKINS ATTACHED DURING THIS PROCESS WILL HELP STIFFEN THE BULKHEADS DURING INSTALLATION.)

BOTTOM FWD SKIN "K"
 MF03-201
 $\triangle D$

TAILWHEEL DOOR STRINGER
 (2) MF04-355

TAILWHEEL DOOR
 (2) MF04-350

LANDING GEAR DOOR HINGE & PIN
 (TWO ON OTHER END OF DOORS)
 $\triangle B$ (4) TC95-260

TAILWHEEL DOOR LINKAGE MOUNT
 (A) MF04-351
 (B) MF04-352

5 1/4"
 5 1/2"

REVISIONS				
E.C. NO.	REV.	DESCRIPTION	BY	DATE
	A	DRAWING RELEASED	CE	01/04
0124	B	CHANGED PART NUMBER	CE	9/04
0520	C	NOTES ADDED	SH	8/07
0743	D	NOTES CHANGED	SH	7/08

TITAN AIRCRAFT SUPPLY
 1419 STATE ROUTE 45 SOUTH
 AUSTINBURG, OHIO 44010

DETAIL NAME		TAILWHEEL DOOR INSTALLATION		
SCALE		1/4"=1"	PART NO.	
ASSEMBLY NAME				
PART NO.			DRAWING NO.	
DRAWING NO.		B T51-04-INS-1024-D		

DRAWN	DATE
C. EMERY	1/23/04
CHECKED	DATE
APPROVED	DATE