

REVISIONS				
E.C. NO.	REV.	DESCRIPTION	BY	DATE
	A	DRAWING RELEASED	BH	2/10

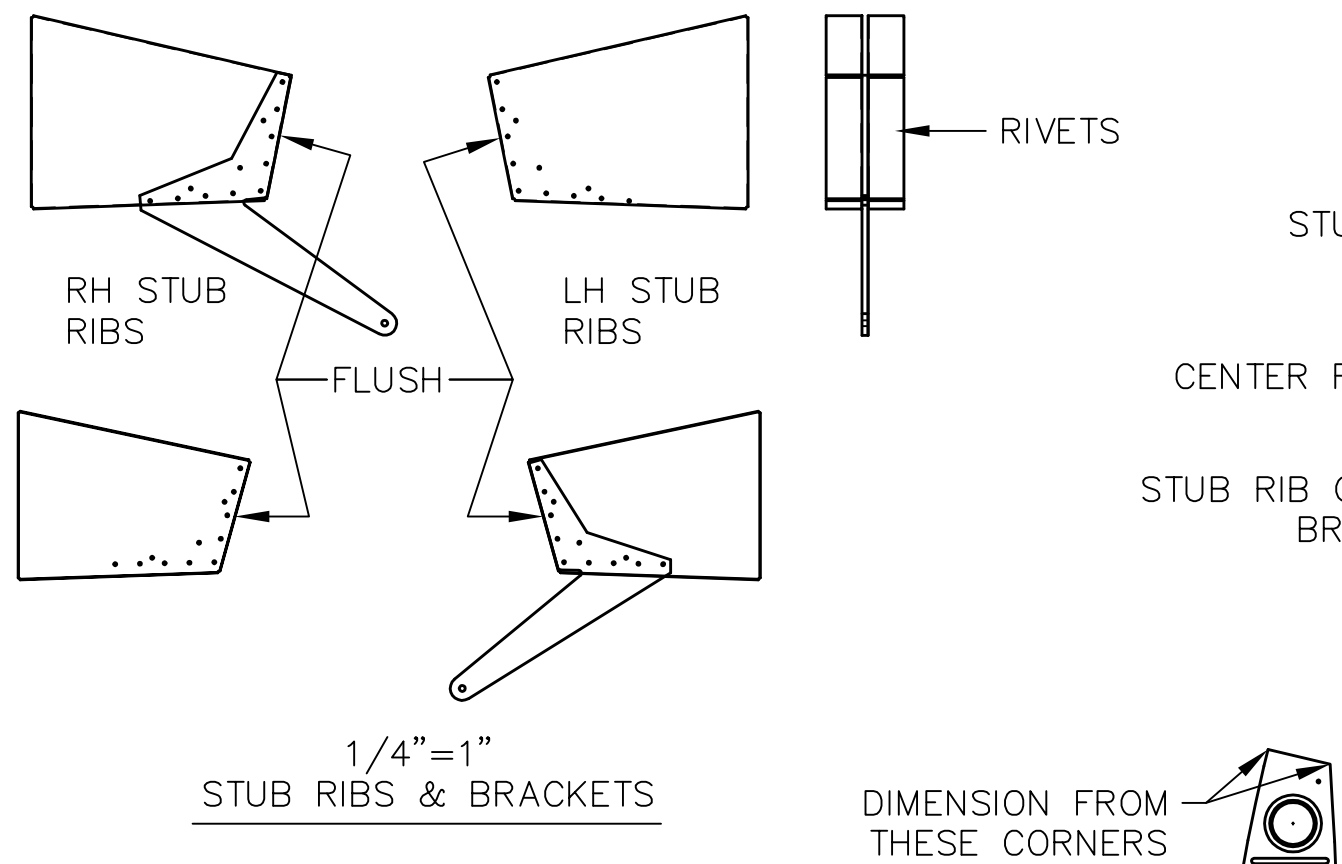

**NOTES:**

- IT IS RECOMMENDED TO INSTALL THE CENTER FLAP BRACKETS WHEN MOUNTING THE FLAP TO THE INNER AND OUTER FLAP BRACKETS.
- BRACKETS ARE 90° FROM THE MAIN SPAR & PARALLEL WITH THE WING RIBS.
- DRILL THE STUB RIBS USING THE FLAP BRACKETS AS DRILL GUIDES.
- SANDWICH EACH FLAP BRACKET BETWEEN THE LH & RH STUB RIBS. (USE SD45BS RIVETS TO ASSEMBLE.)
- DRILL AND RIVET THE FLAP BRACKETS TO THE REAR SPAR AND INTERMEDIATE WEBS. (WHEN SATISFIED USE SD42BS RIVETS)
- DIMENSIONS ARE TAKEN FROM THE TOP & BOTTOM EDGE OF THE REAR SPAR.
- ALSO REFER TO DRAWINGS T51-02-INS-0387 & T51-10-INS-1874 FOR ADDITIONAL INFORMATION.

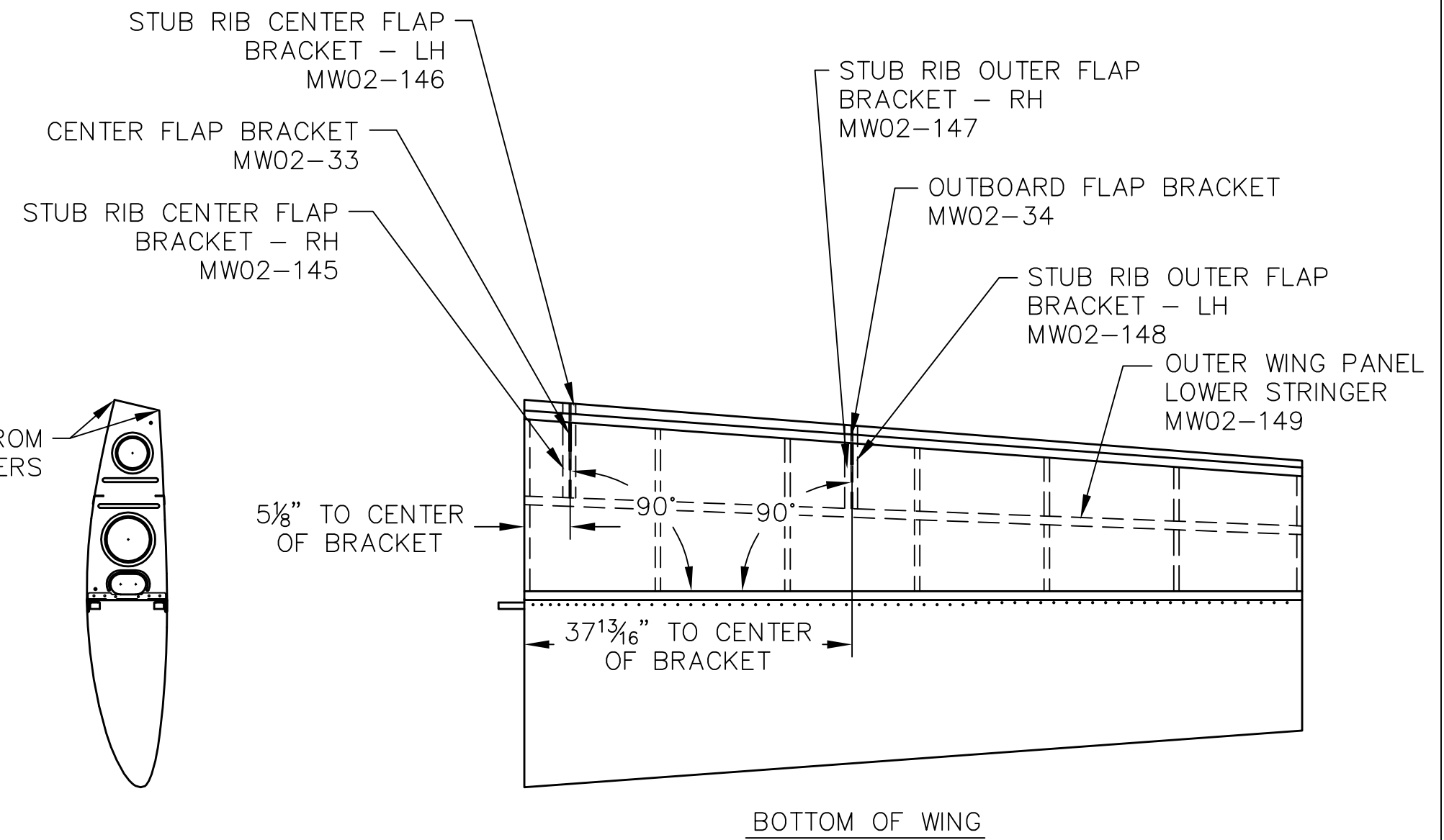

THIS DOCUMENT PROPRIETARY TO TITAN AIRCRAFT, AND IS NOT TO BE USED, CIRCULATED, REPRODUCED, COPIED, OR DISCLOSED IN ANY MANNER WITHOUT PRIOR WRITTEN PERMISSION OF AN AUTHORIZED OFFICIAL OF TITAN AIRCRAFT.

**TITAN AIRCRAFT SUPPLY**  
 1419 STATE ROUTE 45 SOUTH  
 AUSTINBURG, OHIO 44010

DRAWN B. HARE		DATE 2/16/10	DETAIL NAME FLAP STUB RIB INSTALLATION	
CHECKED R. INGLE		DATE 2/16/10	SCALE 1/16"=1"	PART NO.
APPROVED K. BROOKS		DATE 2/16/10	ASSEMBLY NAME FOR A/C SERIAL # 152 & LATER	
			PART NO.	DRAWING NO. S15
			DRAWING NO. <b>B T51-10-INS-1877-A</b>	