

REVISIONS				
E.C. NO.	REV.	DESCRIPTION	BY	DATE
	A	DRAWING RELEASED	KL	2/03
0096	B	ADDED WING SKIN STRIP	CE	5/04
0454	C	UPDATED DRAWING	SH	3/07

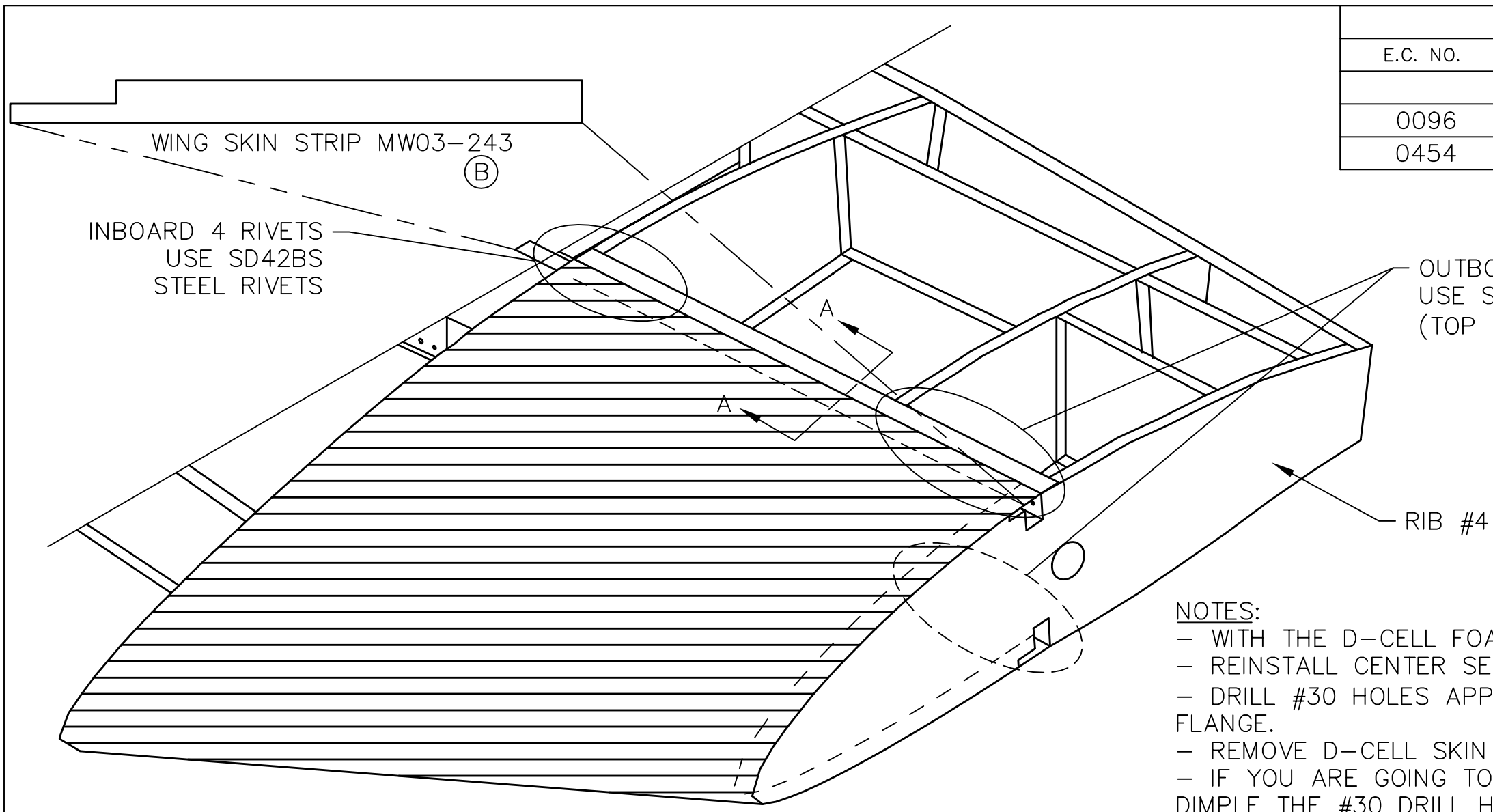

- NOTES:**
- WITH THE D-CELL FOAM IN PLACE, CLECO FLANGES TO RIB #4.
 - REINSTALL CENTER SECTION FWD D-CELL SKIN.
 - DRILL #30 HOLES APPROX. 1½" APART THRU SKIN AND CENTER OF FLANGE.
 - REMOVE D-CELL SKIN AND REMOVE CENTER SECTION FOAM.
 - IF YOU ARE GOING TO USE FLUSH RIVETS, YOU WILL NEED TO DIMPLE THE #30 DRILL HOLES ON THE FLANGES AND D-CELL SKIN.
 - COMPLETE FINAL FIT BEFORE INSTALLING SKINS.
 - CLEAN ALL SURFACES, BOND AND RIVET FLANGES TO THE RIB.

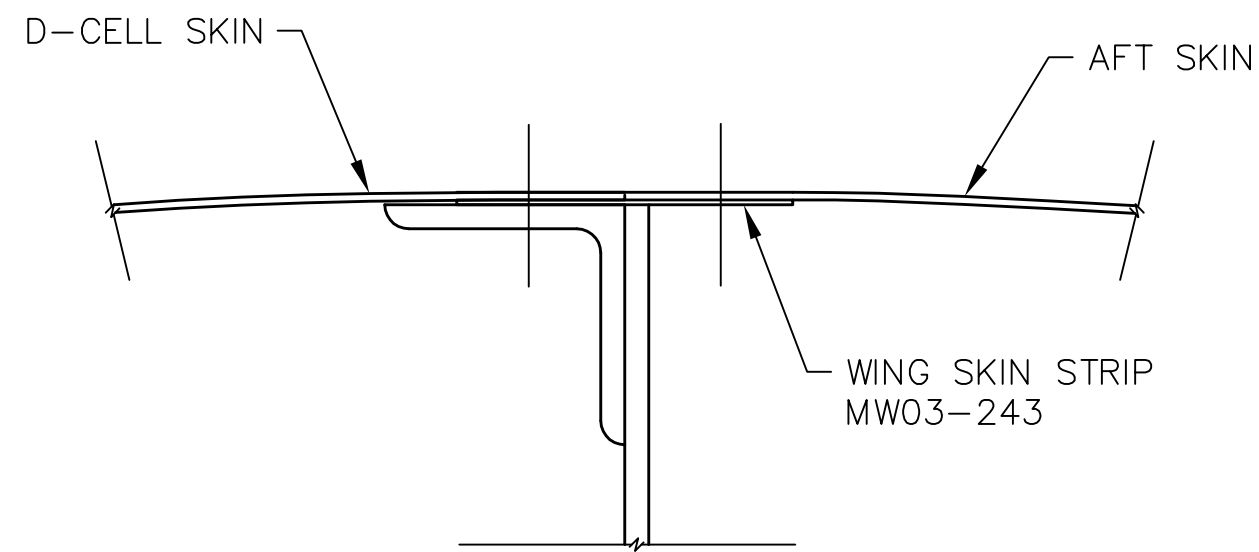

SECTION A-A

TITAN AIRCRAFT SUPPLY
 1419 STATE ROUTE 45 SOUTH
 AUSTINBURG, OHIO 44010

DETAIL NAME #4 RIB FLANGE INSTALLATION	
SCALE 1/8"=1"	PART NO.
ASSEMBLY NAME	
PART NO.	DRAWING NO.
DRAWING NO. B T51-03-INS-0604-C	

DRAWN K. LIPLIN	DATE 2/7/03
CHECKED MSH	DATE 4/12/07
APPROVED JW	DATE 4/27/07

THIS DOCUMENT PROPRIETARY TO TITAN AIRCRAFT, AND IS NOT TO BE USED, CIRCULATED, REPRODUCED, COPIED, OR DISCLOSED IN ANY MANNER WITHOUT PRIOR WRITTEN PERMISSION OF AN AUTHORIZED OFFICIAL OF TITAN AIRCRAFT.