

REVISIONS				
E.C. NO.	REV.	DESCRIPTION	BY	DATE
	B	HINGE PATTERN WAS PREDRILLED	K.B.	8/95
1897	C	DIMENSION WERE ADDED	KL	3/01

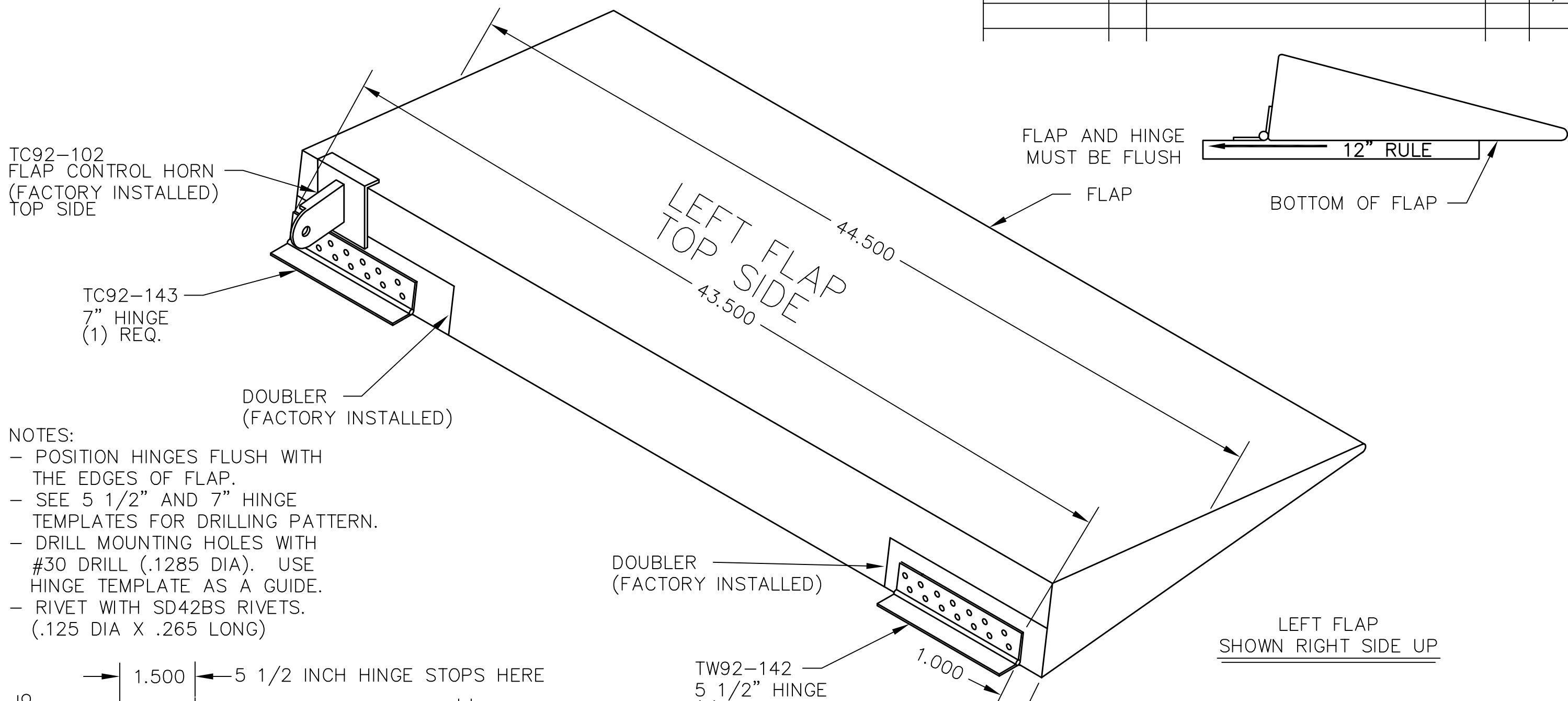

TC92-102
FLAP CONTROL HORN
(FACTORY INSTALLED)
TOP SIDE

TC92-143
7" HINGE
(1) REQ.

DOUBLER
(FACTORY INSTALLED)

- NOTES:
- POSITION HINGES FLUSH WITH THE EDGES OF FLAP.
 - SEE 5 1/2" AND 7" HINGE TEMPLATES FOR DRILLING PATTERN.
 - DRILL MOUNTING HOLES WITH #30 DRILL (.1285 DIA). USE HINGE TEMPLATE AS A GUIDE.
 - RIVET WITH SD42BS RIVETS. (.125 DIA X .265 LONG)

DOUBLER
(FACTORY INSTALLED)

TW92-142
5 1/2" HINGE
(1) REQ.

LEFT FLAP
SHOWN RIGHT SIDE UP

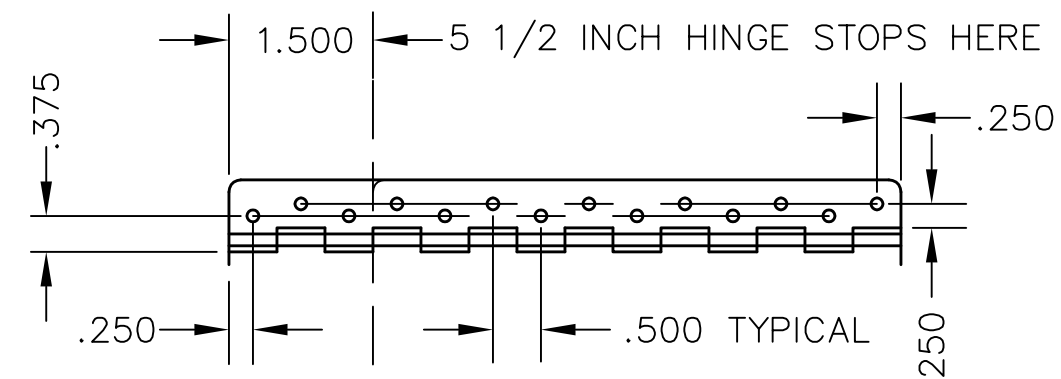

VIEW A: HINGE DRILL DIMENSIONS(SEE TEMPLATE)
BOTH SIDES OF HINGE TYPICAL

TITAN AIRCRAFT SUPPLY
1419 STATE ROUTE 45 SOUTH
AUSTINBURG, OHIO 44010

DETAIL NAME		FLAP HINGE INSTALLATION	
DRAWN	J. PRESTON	DATE	9/3/92
CHECKED		DATE	
APPROVED		DATE	
SCALE		N/A	
PART NO.		N/A	
ASSEMBLY NAME		SINGLE SEAT 20 FT. WING	
PART NO.		N/A	
DRAWING NO.		B92-INS-0259-C	

THIS DOCUMENT PROPRIETARY TO TITAN AIRCRAFT, AND IS NOT TO BE USED, CIRCULATED, REPRODUCED, COPIED, OR DISCLOSED IN ANY MANNER WITHOUT PRIOR WRITTEN PERMISSION OF AN AUTHORIZED OFFICIAL OF TITAN AIRCRAFT.