

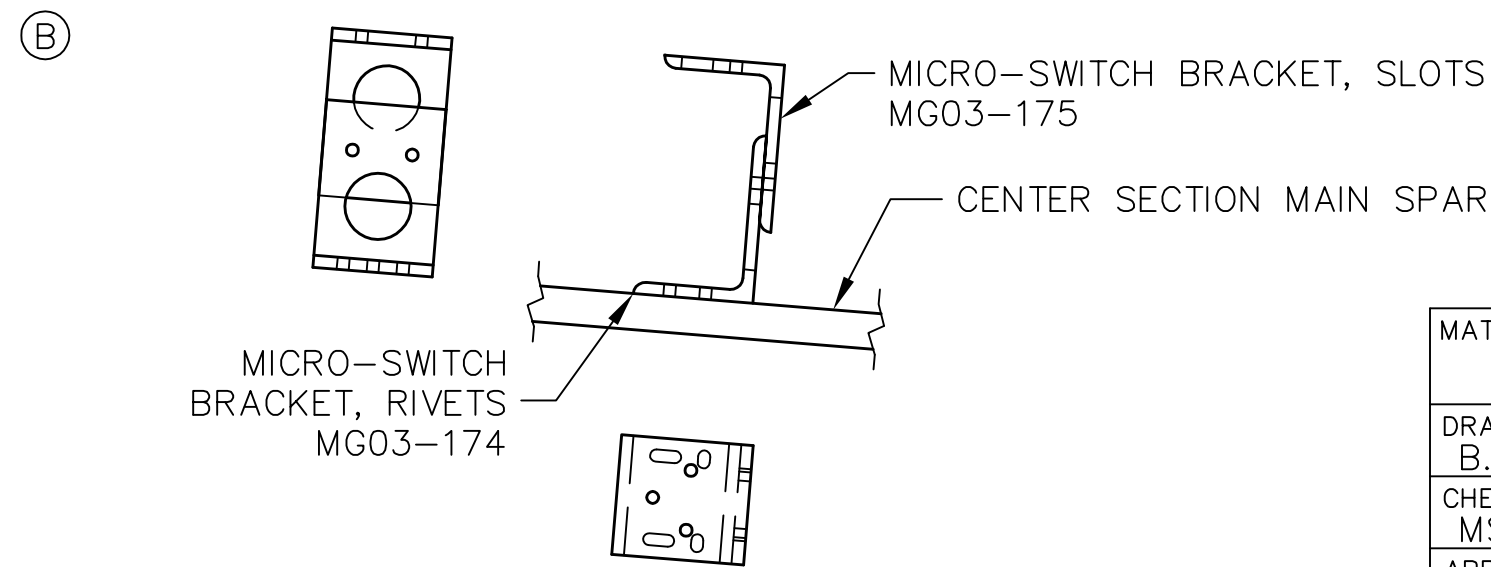

NOTE:
 - FINAL MOUNTING POSITION SHOULD BE DETERMINED BY OPERATING GEAR THROUGH ITS FULL RANGE.
 - MAKE SURE THAT THE LIMIT SWITCH IS ACTIVATED WHEN LANDING GEAR IS FULL UP AND WHEEL IS INSIDE WHEEL WELL.
 - ***DIMENSIONS ARE FOR REFERENCE ONLY.***

REVISIONS				
E.C. NO.	REV.	DESCRIPTION	BY	DATE
	A	DRAWING RELEASED	BH	10/03
0116	B	ADDED NOTE	CE	8/04
0373	C	NOTES ADDED	SH	11/06

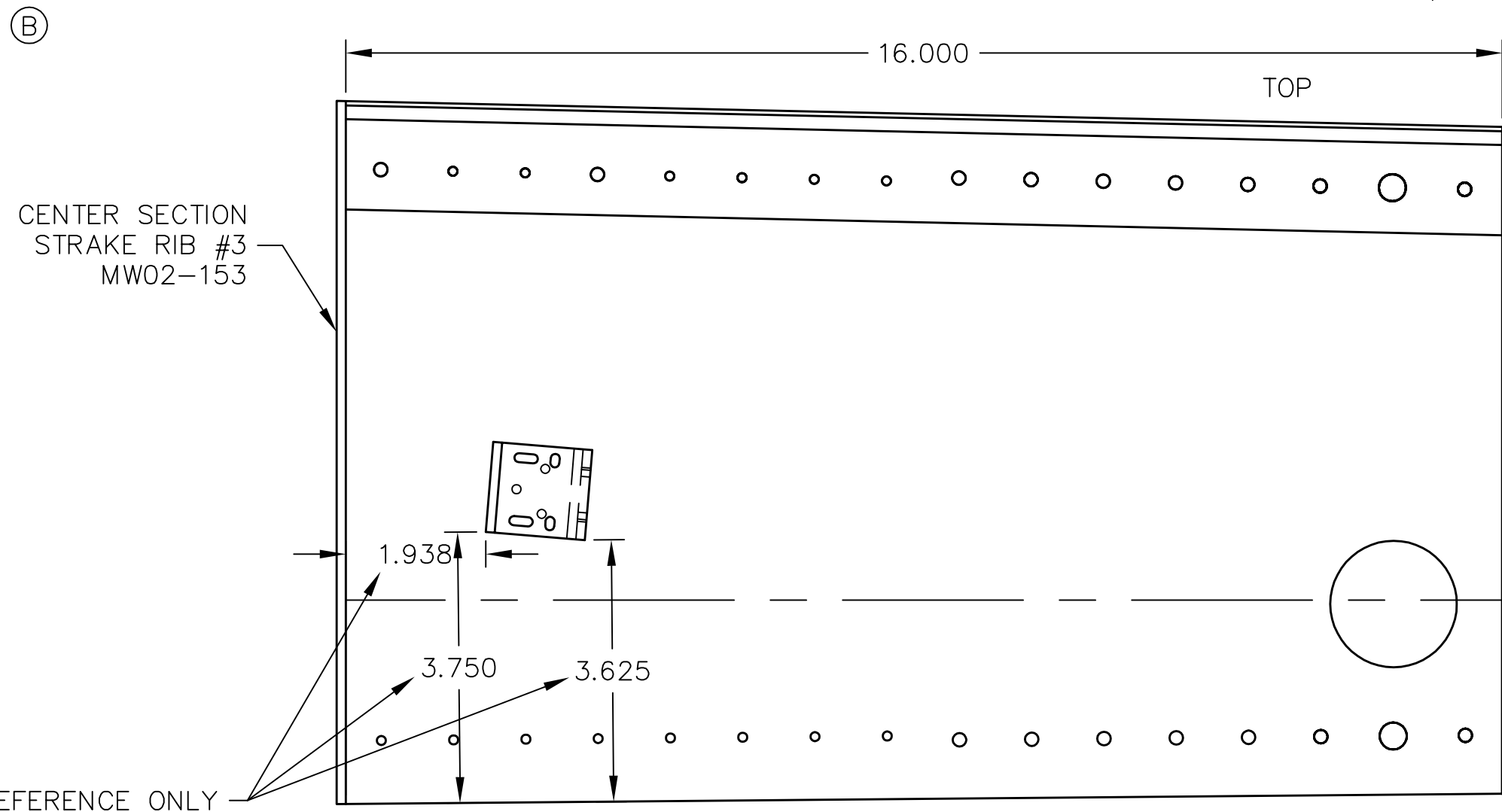

NOTE:
 -VIEW LOOKING BACK FROM INSIDE THE MAIN GEAR WHEEL WELL.

 TITAN AIRCRAFT SUPPLY 1419 STATE ROUTE 45 SOUTH AUSTINBURG, OHIO 44010	
DETAIL NAME UP SWITCH BRACKET INSTALLATION	
SCALE N/A	PART NO.
ASSEMBLY NAME	
PART NO.	DRAWING NO.
DRAWING NO. B T51-03-INS-0927-C	

MATERIAL	
DRAWN B. HODGKINSON	DATE 10-14-03
CHECKED MSH	DATE 12/6/06
APPROVED JW	DATE 12/27/06

THIS DOCUMENT PROPRIETARY TO TITAN AIRCRAFT, AND IS NOT TO BE USED, CIRCULATED, REPRODUCED, COPIED, OR DISCLOSED IN ANY MANNER WITHOUT PRIOR WRITTEN PERMISSION OF AN AUTHORIZED OFFICIAL OF TITAN AIRCRAFT.