

REVISIONS				
E.C. NO.	REV.	DESCRIPTION	BY	DATE
	A	DRAWING RELEASED	CE	2/04
0178	B	ADDED PART NUMBER	CE	10/05
0510	C	DRAWING UPDATED	SH	8/07
0545	D	DIMENSION ADDED	SH	10/07
0803	E	TOP VIEW ADDED	SH	11/08

**NOTE:**  
 - THE SIDE SKINS WILL RIVET TO MF03-207.  
 - REFER TO DRAWING T51-06-INS-1487 FOR MORE INSTRUCTIONS ON FIREWALL INSTALLATION.  
 - BOND AND RIVET THE STAINLESS STEEL FIREWALL (MF03-199) TO STATION #2 BULKHEADS, FORMERS, & HAT SECTIONS W/ SD42BS RIVETS.

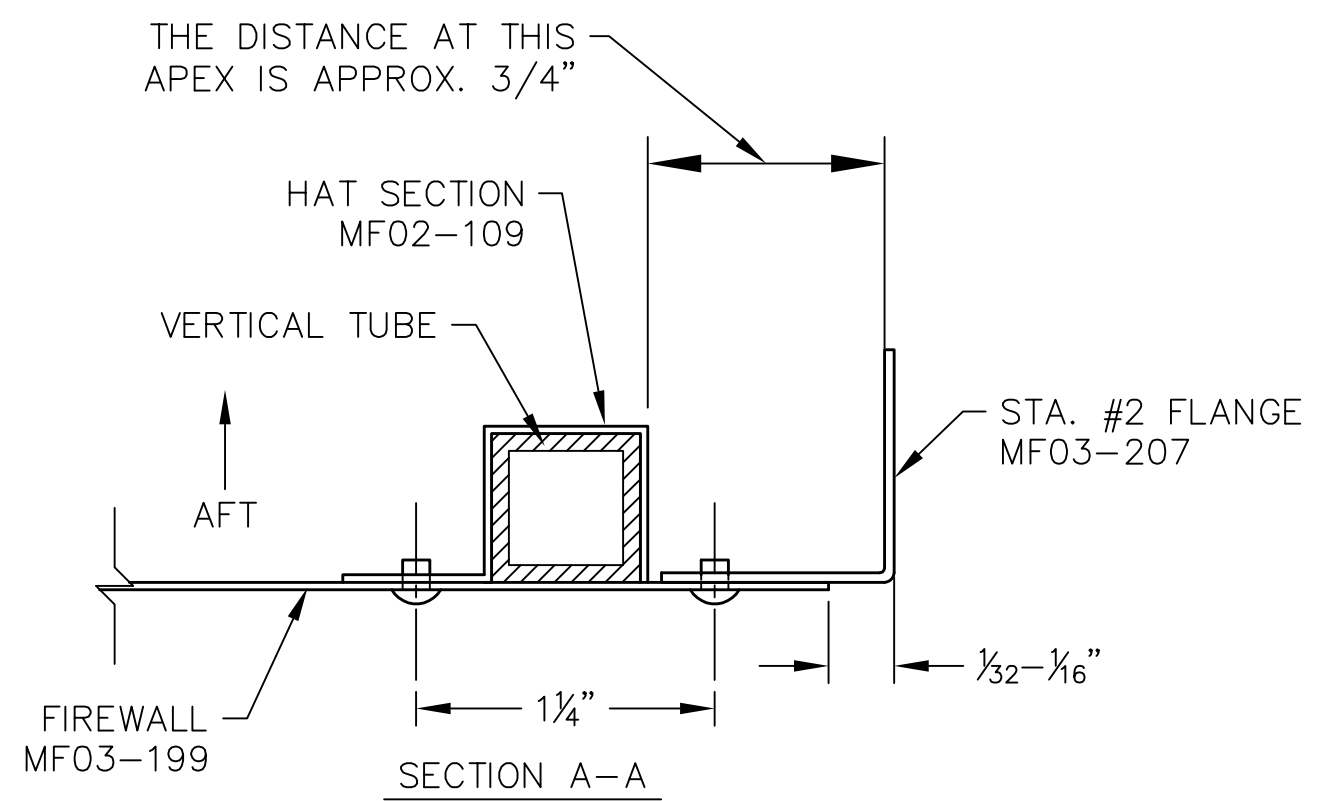
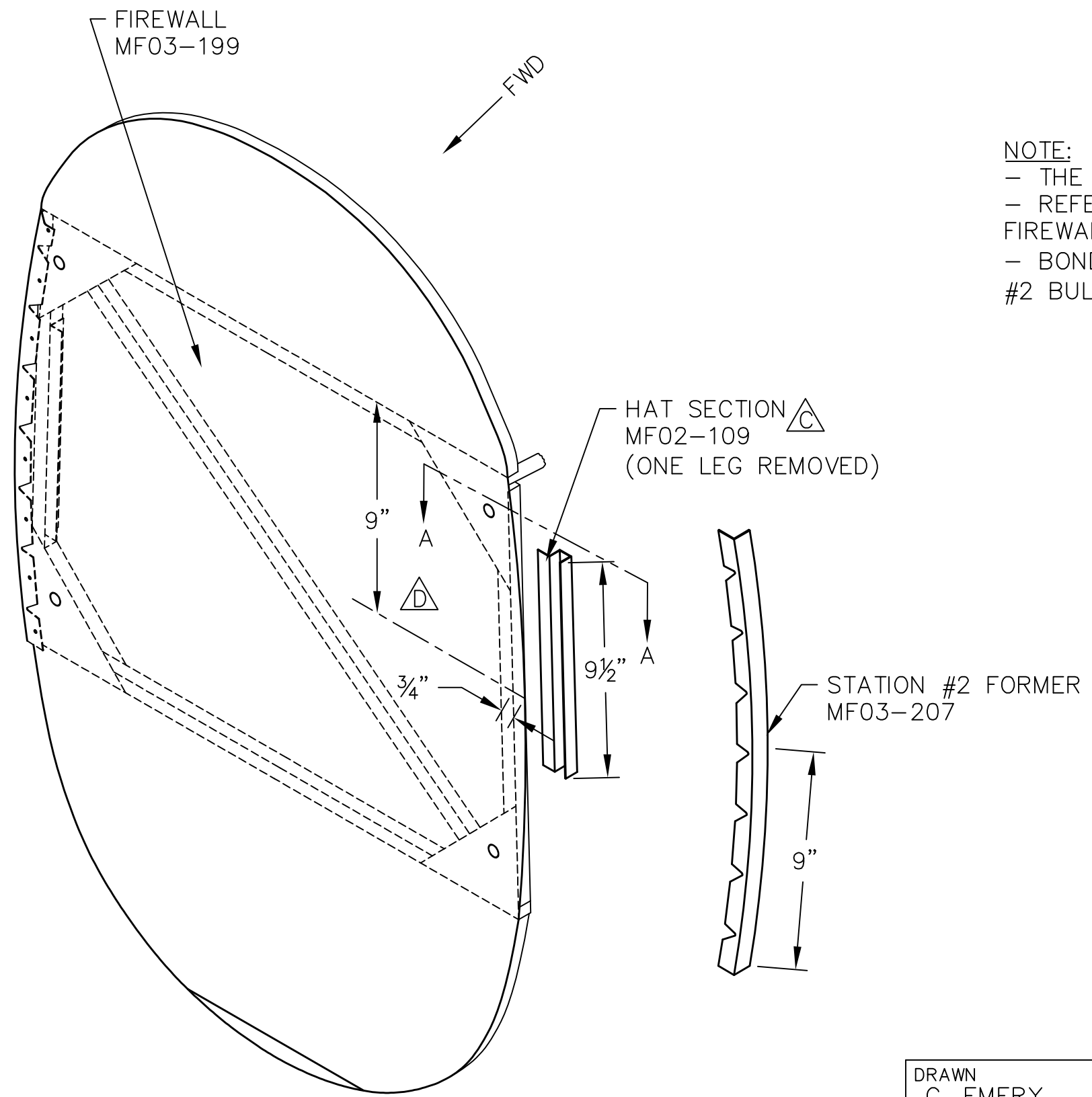

**TITAN AIRCRAFT SUPPLY**  
 1419 STATE ROUTE 45 SOUTH  
 AUSTINBURG, OHIO 44010

DETAIL NAME FUSELAGE FORMER - STA. #2 INSTRUCTIONAL  
 SCALE 3/16"=1" PART NO.  
 ASSEMBLY NAME  
 PART NO. DRAWING NO. F7  
 DRAWING NO. **B T51-04-INS-1053-E**

DRAWN C. EMERY DATE 2/26/04  
 CHECKED RI DATE 1/26/09  
 APPROVED KORY B. DATE 1/28/09

THIS DOCUMENT PROPRIETARY TO TITAN AIRCRAFT, AND IS NOT TO BE USED, CIRCULATED, REPRODUCED, COPIED, OR DISCLOSED IN ANY MANNER WITHOUT PRIOR WRITTEN PERMISSION OF AN AUTHORIZED OFFICIAL OF TITAN AIRCRAFT.