

THIS DOCUMENT PROPRIETARY TO TITAN AIRCRAFT, AND IS NOT TO BE USED, CIRCULATED, REPRODUCED, COPIED, OR DISCLOSED IN ANY MANNER WITHOUT PRIOR WRITTEN PERMISSION OF AN AUTHORIZED OFFICIAL OF TITAN AIRCRAFT.

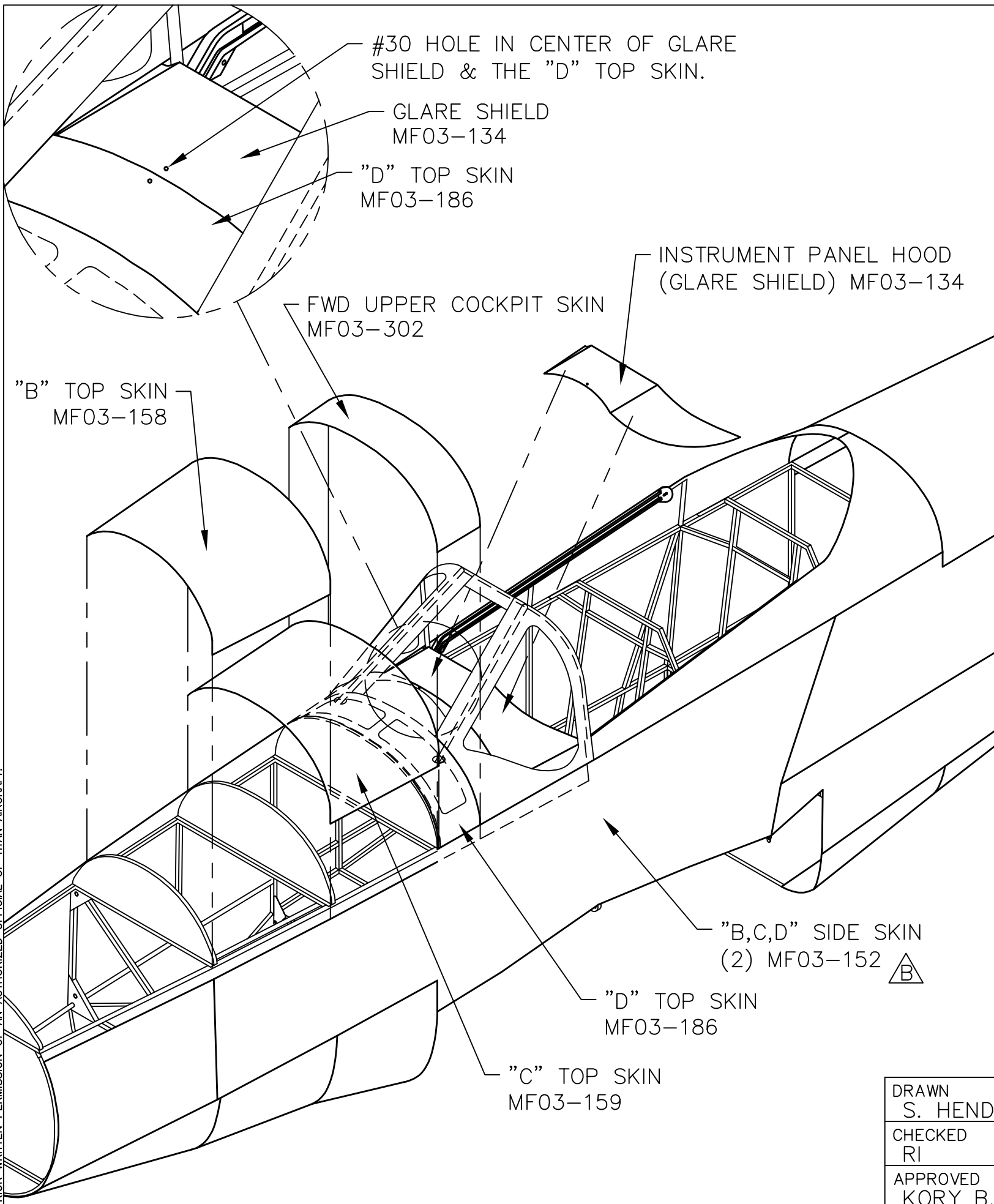

REVISIONS				
E.C. NO.	REV.	DESCRIPTION	BY	DATE
	A	DRAWING RELEASED	SH	12/05
0851	B	MF03-152 CHANGED	SH	1/09

NOTES:

- WITH THE "D" TOP SKIN IN PLACE, THE LOWER EDGES ARE TO BE TUCKED BETWEEN THE "D" SIDE SKINS AND THE TOP LONGERON.
- THE "C" TOP SKIN OVERLAPS THE "D" TOP SKIN AT BULKHEAD #4.
- THE "B" TOP SKIN BUTTS UP TO THE "C" TOP SKIN. (THESE SKINS WILL HAVE TO BE OVERLAPPED BY THE SIDE SKINS.)
- WITH THE GLARE SHIELD CENTERED, DRILL & CLECO THE GLARE SHIELD TO THE "D" TOP SKIN. DRILL A #30 HOLE THRU BOTH PIECES ON THE CENTER LINE APPROX. 1 3/4" IN FROM THE TOP AFT EDGE OF THE D-TOP SKIN & APPROX. 1/4" IN FROM THE FWD EDGE OF THE GLARE SHIELD. THE WINGS OF THE GLARE SHIELD ARE PULLED DOWN ALONG THE "D" TOP SKIN SIDES, THEY MAY NEED TO BE TRIMMED TO CLEAR THE SIDE SKIN.
- SET THE ANGLE OF THE GLARE SHIELD TO YOUR PERSONAL PREFERENCE, WE SUGGEST YOU LOOK AT PICTURES OF THE MUSTANG INSTRUMENT PANELS TO HELP IN DECIDING ON THE GLARE SHIELD ANGLE AND SHAPE. WHEN SATISFIED DRILL AND CLECO THE GLARE SHIELD TO THE "D" TOP SKIN. THE WINDSCREEN SIDE TRIM WILL FIT OVER THE GLARE SHIELD AND BETWEEN THE SIDE SKIN AND THE UPPER LONGERON.
- TRIM "D" TOP SKIN ALONG THE RIVET PATTERN FOR THE GLARE SHIELD. REMOVE GLARE SHIELD OR PUT CLECOES IN FROM BOTTOM INSIDE OF "D" TOP SKIN WHEN FITTING WINDSCREEN TRIM PIECES. (REFER TO DRAWING T51-03-INS-0960) FOR PART NUMBERS.
- WINDSCREEN TRIM IS FIT TO THE DOWN TUBES, WHERE THE 15° BEND IS CENTERED ON THE DOWN TUBES. (DO NOT CUT OUT THE WINDOW OPENINGS.) THE MATERIAL IS LIGHT AND IT MAY BE DIFFICULT TO HOLD PROPER SHAPE. WINDOWS ARE ONE OF THE LAST STEPS IN ASSEMBLY. AT THE FWD EDGE OF THE SIDE AND CENTER TRIM PIECES DRILL AND CLECO 3/32" HOLES IN THE FINGERS AND "D" TOP SKIN. MATCH DRILL SIDES AT THE UPPER LONGERON HAT SECTIONS. THE TOP CENTER TRIM PIECE IS ATTACHED TO THE COCKPIT BOW AND THE LEXAN WINDOWS USING A HAT SECTION TO CAPTURE THE UPPER COCKPIT BOW. (REFER TO DRAWING T51-03-INS-0960)

DRAWN S. HENDERSON	DATE 12/21/05
CHECKED RI	DATE 1/21/09
APPROVED KORY B.	DATE 1/26/09

		TITAN AIRCRAFT SUPPLY 1419 STATE ROUTE 45 SOUTH AUSTINBURG, OHIO 44010	
DETAIL NAME		FWD SKINS INSTALLATION INSTRUCTIONAL	
SCALE	N/A	PART NO.	
ASSEMBLY NAME			
PART NO.		DRAWING NO. F17	
DRAWING NO.		B T51-05-INS-1319-B	