

THIS DOCUMENT PROPRIETARY TO TITAN AIRCRAFT, AND IS NOT TO BE USED, CIRCULATED, REPRODUCED, COPIED, OR DISCLOSED IN ANY MANNER WITHOUT PRIOR WRITTEN PERMISSION OF AN AUTHORIZED OFFICIAL OF TITAN AIRCRAFT.

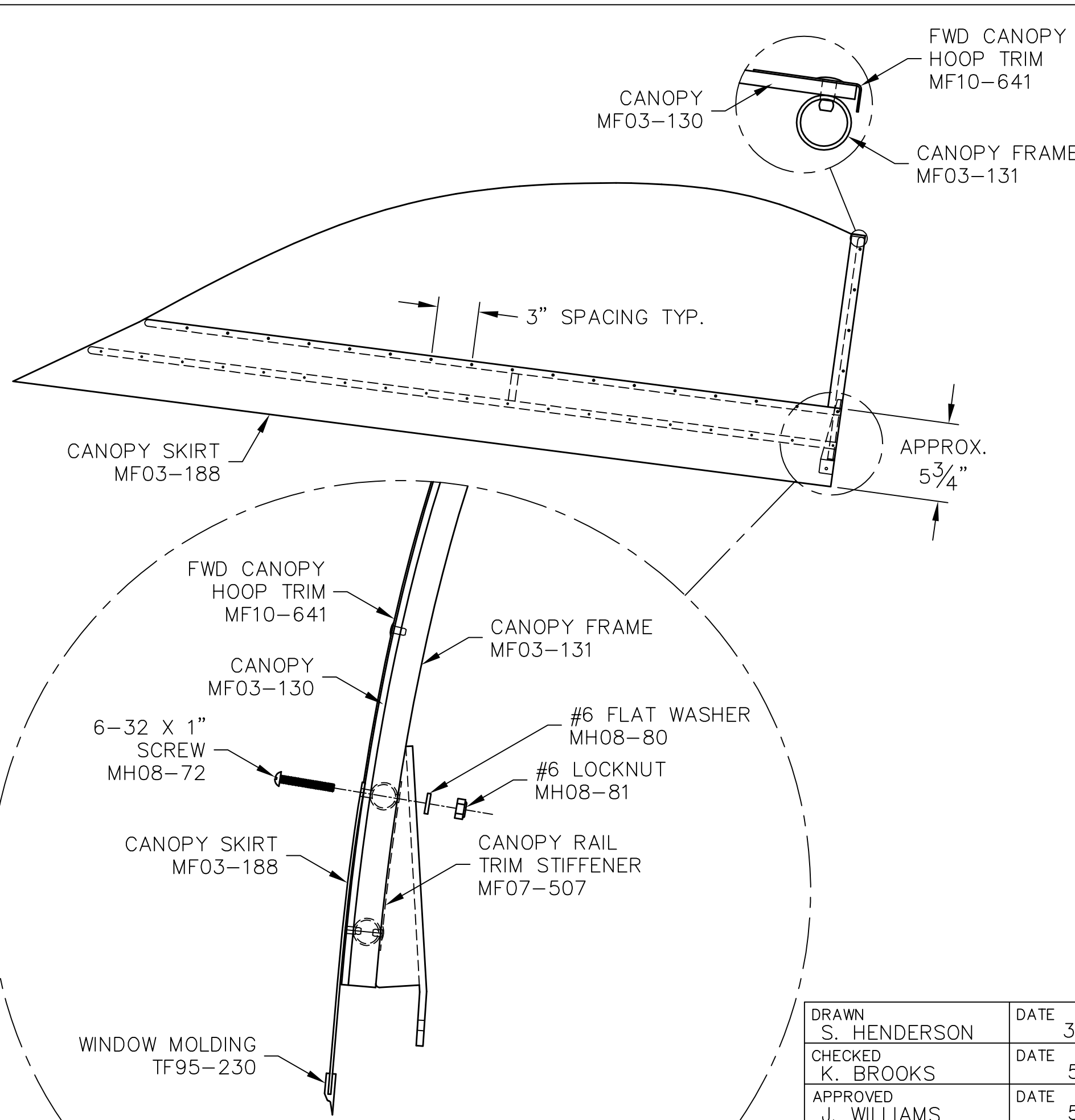

REVISIONS				
E.C. NO.	REV.	DESCRIPTION	BY	DATE
	A	DRAWING RELEASED	SH	3/07
0747	B	NOTES ADDED	SH	8/08
0917	C	NOTES ADDED	SH	3/09

NOTES:

- POSITION THE CANOPY (MF03-130) ON THE CANOPY FRAME (MF03-131) AND CLAMP IT IN PLACE.
- MARK A 3" RIVET PATTERN ON THE BOTTOM CANOPY FRAME RAIL.
- USE A #30 DRILL BIT AND DRILL THROUGH THE CANOPY AND BOTTOM CANOPY FRAME RAIL ON EACH MARK. CLECO AS YOU GO.
- USE AD44ABS RIVETS TO SECURE THE CANOPY TO THE BOTTOM CANOPY FRAME RAIL. TO MINIMIZE THE POSSIBILITY OF CRACKING THE CANOPY, ONLY USE A HAND RIVET GUN DURING THE ENTIRE INSTALLATION.
- INSTALL THE CANOPY AND CANOPY FRAME ON THE AIRCRAFT. ADJUST TO ENSURE PROPER FITMENT.
- TAPE THE CANOPY SKIRT (MF03-188) ON THE CANOPY USING THE DIMENSION PROVIDED.
- MARK A 3" RIVET PATTERN APPROXIMATELY 1/4" DOWN FROM TOP EDGE OF THE CANOPY SKIRT.
- USE A #30 DRILL BIT AND DRILL THROUGH THE CANOPY SKIRT, CANOPY, AND TOP CANOPY FRAME RAIL ON EACH MARK. CLECO AS YOU GO.
- TAPE THE CANOPY RAIL TRIM STIFFENER (MF07-507) ONTO THE INNER CANOPY FRAME RAILS.
- MATCH DRILL THE HOLES FROM THE TOP AND BOTTOM RAILS INTO THE CANOPY RAIL TRIM STIFFENER. CLECO AS YOU GO.
- USE AD42ABS RIVETS ON BOTTOM RAIL TO PARTIALLY SECURE THE CANOPY RAIL TRIM STIFFENER.
- REMOVING THE CLECOS ONE SET AT A TIME, ENLARGE THE #30 HOLES ON THE TOP RAIL TO 5/64". INSTALL THE HARDWARE LISTED AS YOU GO.
- CLAMP THE FWD CANOPY HOOP TRIM (MF10-641) IN PLACE.
- MARK A 3" RIVET PATTERN AROUND THE HOOP OF THE CANOPY FRAME.
- USE A #30 DRILL BIT AND DRILL THROUGH THE FWD CANOPY HOOP TRIM, CANOPY, AND HOOP ON EACH MARK. CLECO AS YOU GO.
- USE AD44ABS RIVETS TO SECURE THE FWD CANOPY HOOP TRIM.
- USE WEATHERSTRIP ADHESIVE TO SECURE THE WINDOW MOLDING (TF95-230) ON THE BOTTOM EDGE OF THE CANOPY SKIRT.

TITAN AIRCRAFT SUPPLY
 1419 STATE ROUTE 45 SOUTH
 AUSTINBURG, OHIO 44010

DRAWN S. HENDERSON		DATE 3/27/07	DETAIL NAME CANOPY SKIRT & HOOP INSTALLATION	
CHECKED K. BROOKS		DATE 5/14/13	SCALE 1/8"=1"	PART NO.
APPROVED J. WILLIAMS		DATE 5/14/13	ASSEMBLY NAME	
			PART NO.	DRAWING NO. F32
			DRAWING NO. B T51-07-INS-1607-C	