

REVISIONS				
E.C. NO.	REV.	DESCRIPTION	BY	DATE
	B	HINGE HOLES WERE PREDRILLED	K.B.	8/95
1859	C	ADDED PART NUMBERS	KL	3/01
1925	D	WAS 67.500 & 66.500	KL	4/01
2091	E	ADDED PART NUMBERS FOR HINGES	KL	10/02

TC92-102
FLAP CONTROL HORN
(FACTORY INSTALLED)

TOP SIDE

TC92-143 (ROLLED)
TC95-261 (EXTRUDED, [ⓔ])
USED IN VNE PACKAGE)
(1)-REQUIRED

DOUBLER
(FACTORY INSTALLED)

TC92-142 (ROLLED)
TC95-260 (EXTRUDED, [ⓔ])
USED IN VNE PACKAGE)
(2)-REQUIRED

DOUBLER
(FACTORY INSTALLED)

TC92-142 (ROLLED) [ⓔ]
TC95-260 (EXTRUDED,
USED IN VNE PACKAGE)

USE A STRAIGHT EDGE
TO MAKE
FLAP AND HINGE
FLUSH

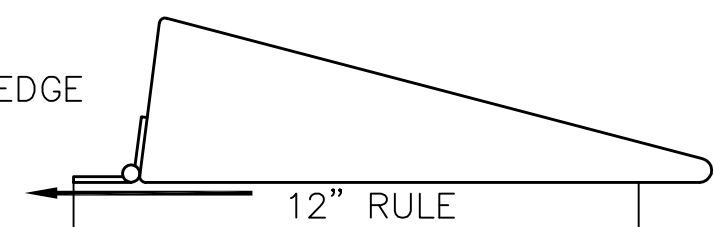

FLAP
TC92-122 L
TC92-121 R

- NOTES:
- HINGES ARE NOT PREDRILLED. USE 5 1/2" AND 7" HINGE TEMPLATES FOR DRILL PATTERN.
 - POSITION OUTER HINGES FLUSH WITH THE EDGES OF FLAP.
 - POSITION CENTER HINGE ON THE CENTER LINE OF DOUBLER.
 - DRILL MOUNTING HOLES WITH #30 DRILL (.1285 DIA). USE HINGE TEMPLATE AS A GUIDE.
 - RIVET WITH SD42BS RIVETS. (.125 DIA X .265 LONG)

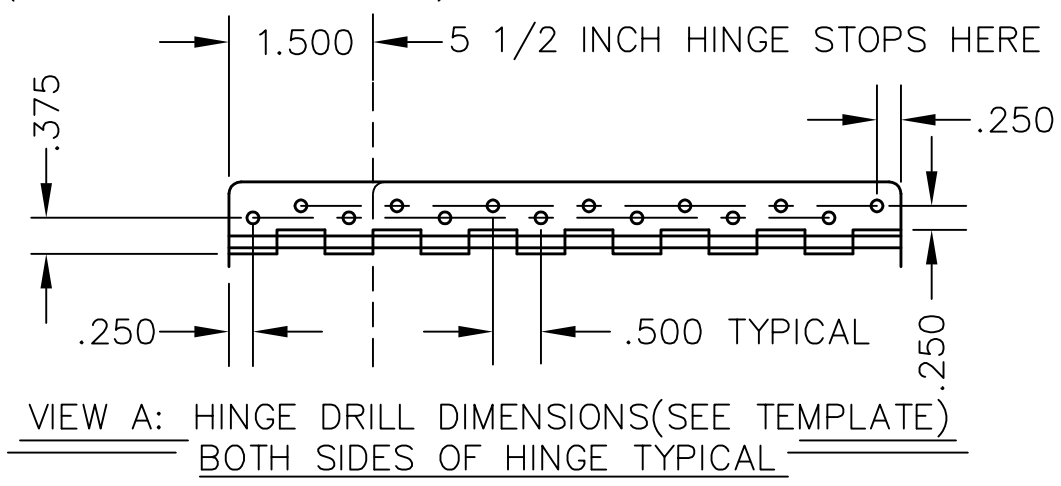

ALL HINGES ON
BOTTOM SIDE

TITAN AIRCRAFT SUPPLY
1419 STATE ROUTE 45 SOUTH
AUSTINBURG, OHIO 44010

DETAIL NAME		FLAP HINGE INSTALLATION	
DRAWN	DATE	SCALE	PART NO.
J. PRESTON	2/23/93	N/A	
CHECKED	DATE	ASSEMBLY NAME	
G. TRUEX	10/22/02	TWO PLACE TORNADO 23 1/2 WING	
APPROVED	DATE	PART NO.	DRAWING NO.
J. WILLIAMS	10/23/02		
		DRAWING NO. B 92-INS-0261-E	

THIS DOCUMENT PROPRIETARY TO TITAN AIRCRAFT, AND IS NOT TO BE USED, CIRCULATED, REPRODUCED, COPIED, OR DISCLOSED IN ANY MANNER WITHOUT PRIOR WRITTEN PERMISSION OF AN AUTHORIZED OFFICIAL OF TITAN AIRCRAFT.