

REVISIONS				
E.C. NO.	REV.	DESCRIPTION	BY	DATE
	A	DRAWING RELEASED	HO	6/98
1806	B	MADE PART TO PERPORTION	KL	1/01
2035	C	ADDED 10" DIMENSION	KL	11/01
2212	D	MOVED RIB	SH	10/07

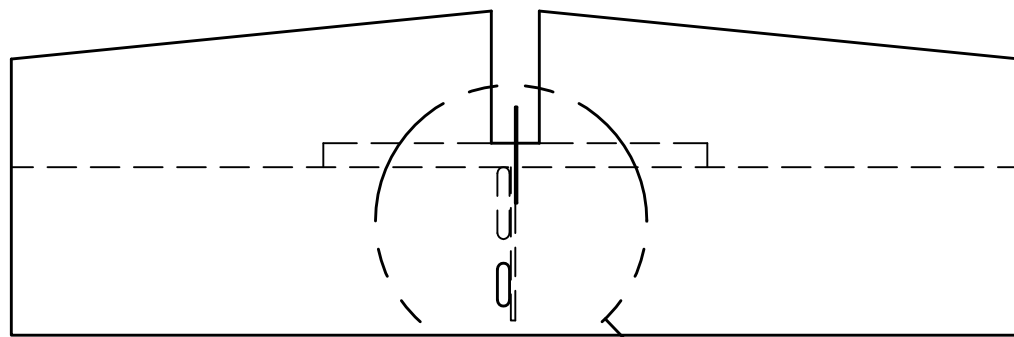

TOP VIEW

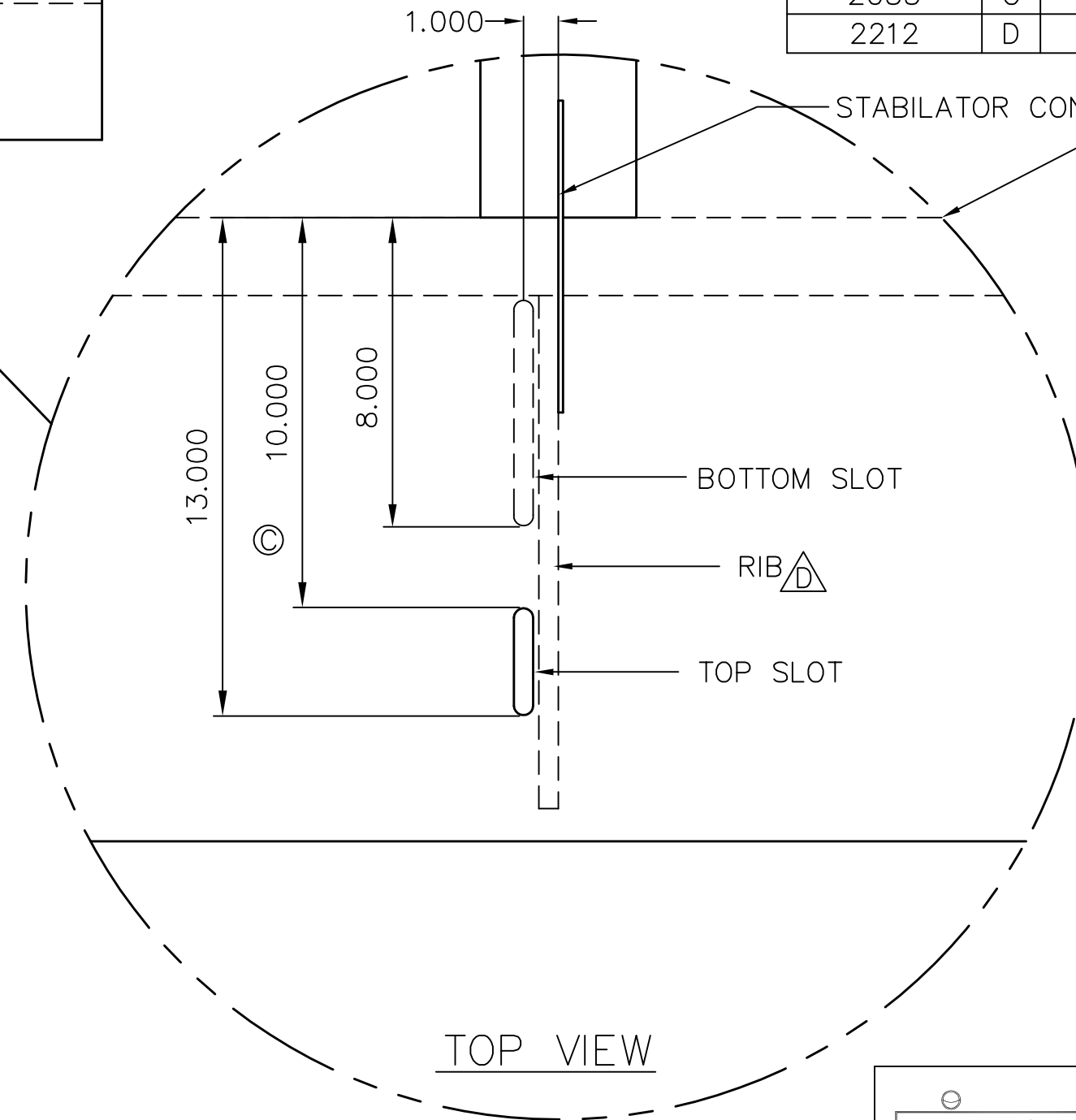

TOP VIEW

NOTES:  
 ALL DIMENSIONS ARE TAKEN IN INCHES AND FROM THE LEADING EDGE OF 2" SPAR.  
 SLOTS ARE 3/8" WIDE.

**TITAN AIRCRAFT SUPPLY**  
 1419 STATE ROUTE 45 SOUTH  
 AUSTINBURG, OHIO 44010

DETAIL NAME		ANTI-SERVO CONTROL ROD SLOTS	
SCALE	1/8" = 1	PART NO.	N/A
ASSEMBLY NAME		7 FT. & 8 FT. STABILATOR	
PART NO.	N/A	DRAWING NO.	
DRAWING NO.		B 98-INS-0970-D	

DRAWN	H. OLAH	DATE	11/19/98
CHECKED		DATE	
APPROVED		DATE	

THIS DOCUMENT PROPRIETARY TO TITAN AIRCRAFT. AND IS NOT TO BE USED, CIRCULATED, REPRODUCED, COPIED, OR DISCLOSED IN ANY MANNER WITHOUT PRIOR WRITTEN PERMISSION OF AN AUTHORIZED OFFICIAL OF TITAN AIRCRAFT.